

3D Geometry Review: Surface Area, and Volume

1. Explain what *surface area* of an object describes.

The space on the outside of the object.
(The "package".)

2. Explain what *volume* of an object describes.

The space on the inside of an object.
(How much it will hold.)

3. When finding the surface area of a pyramid, which height do you use?

Straight Height or

Slant Height

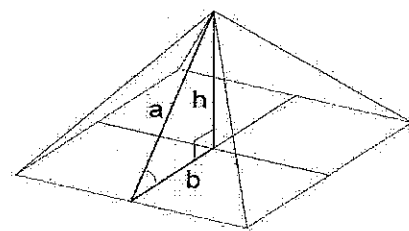

4. When finding the volume of a pyramid, which height do you use?

Straight Height

or

Slant Height

5. Fill in the blanks below...

	<u>Total # of Faces</u>	<u>Shape of Base</u>
a. Triangular Prism	<u>5</u>	<u>triangle</u>
b. Pentagonal Prism	<u>7</u>	<u>pentagon</u>
c. Square Pyramid	<u>5</u>	<u>square</u>
d. Hexagonal Pyramid	<u>7</u>	<u>hexagon</u>

For each of the following...

- ✓ Name the figure
- ✓ Find the Surface Area – show your work.
- ✓ Find the Volume – show your work.

a.

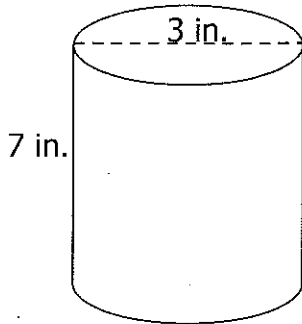

NAME: Cylinder

Surface Area - (Formula: $2\pi r^2 + h \cdot 2\pi r$)

$$SA = 2\pi \cdot 1.5^2 + 7 \cdot 2\pi \cdot 1.5$$

$$SA = 14.13 + 65.94$$

$$SA = \boxed{80.1 \text{ in}^2}$$

Volume - (Formula: $A \text{ of } B \times h$)

$$A = \pi \cdot 1.5^2$$

$$A = 7.065$$

$$V = 7.065 \times 7$$

$$V = \boxed{49.5 \text{ in}^3}$$

b.

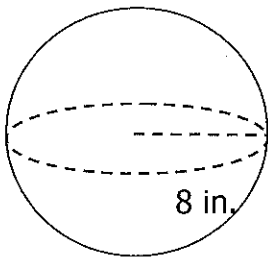

NAME: Sphere

Surface Area - (Formula: $SA = 4\pi r^2$)

$$SA = 4 \cdot \pi \cdot 8^2$$

$$SA = \boxed{803.8 \text{ in}^2}$$

Volume - (Formula: $\frac{4}{3}\pi r^3$)

$$V = \frac{4}{3} \pi \cdot 8^3 = \boxed{2143.6 \text{ in}^3}$$

c.

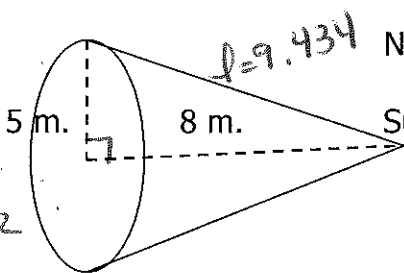

NAME: Cone

Surface Area - (Formula: $\pi r^2 + \pi \cdot r \cdot l$)

$$SA = \pi \cdot 5^2 + \pi \cdot 5 \cdot 9.434$$

$$SA = 78.5 + 148.114$$

$$SA = \boxed{226.6 \text{ m}^2}$$

Volume - (Formula: $\frac{1}{3} \cdot A \text{ of } B \cdot h$)

$$A = \pi r^2$$

$$A = \pi \cdot 5^2$$

$$A = 78.5$$

$$V = \frac{1}{3} \cdot 78.5 \cdot 8$$

$$V = \boxed{209.3 \text{ m}^3}$$

$$5^2 + 8^2 = l^2$$

$$25 + 64 = l^2$$

$$\sqrt{89} = \sqrt{l^2}$$

$$l \approx 9.434$$

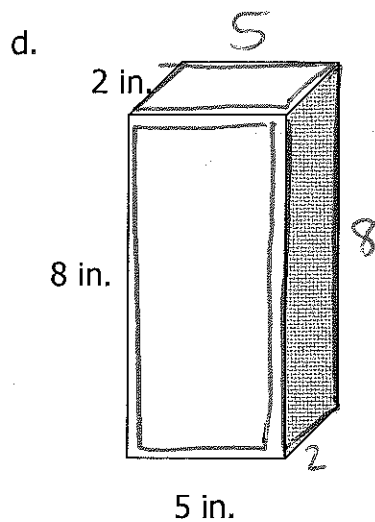

$$A = 2 \times 5$$

$$A = 10$$

NAME: Rectangular Prism

Surface Area:

<u>T+B</u>	<u>Sides</u>	<u>B+H</u>
$2 \times 5 = 10$	$8 \cdot 2 = 16$	$8 \cdot 5 = 40$
$10 \times 2 = 20$	$16 \times 2 = 32$	$40 \times 2 = 80$

$$20 + 32 + 80 = 132 \text{ in}^2$$

Volume:

$$V = A \text{ of } B \times \text{height}$$

$$V = 10 \cdot 8$$

$$V = 80 \text{ in}^3$$

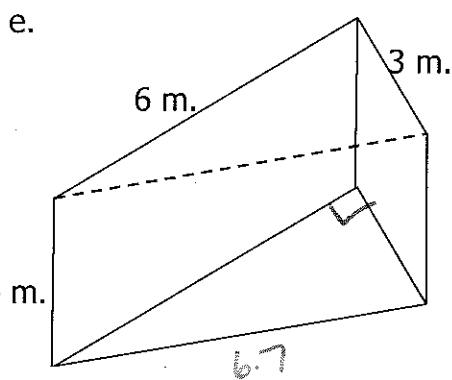

$$a^2 + b^2 = c^2$$

$$3^2 + 6^2 = c^2$$

$$9 + 36 = c^2$$

$$\sqrt{45} = c$$

$$c \approx 6.7$$

$$A = \frac{1}{2} \cdot b \cdot h$$

$$A = \frac{1}{2} \cdot 6 \cdot 3$$

$$A = 9$$

NAME: Triangular Prism

Surface Area:

2 Triangles (same)

$$A = \frac{1}{2} \cdot b \cdot h$$

$$A = \frac{1}{2} \cdot 6 \cdot 3$$

$$A = 9$$

$$9 \times 2 = 18$$

Volume:

$$V = A \text{ of } B \times h$$

$$V = 9 \cdot 4$$

$$V = 36 \text{ m}^3$$

3 rectangles (Diff)

$$6 \cdot 4 = 24$$

$$3 \cdot 4 = 12$$

$$6.7 \cdot 4 = 26.8$$

62.8

$$18 + 62.8 = 80.8 \text{ m}^2$$

f.

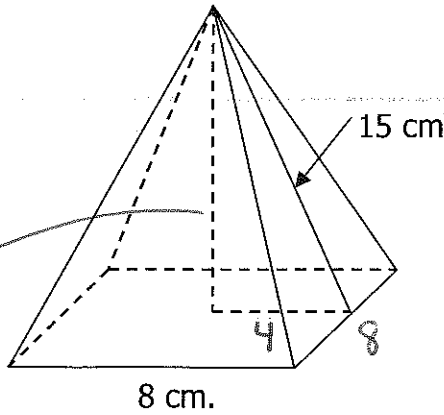

NAME: Square Pyramid

Surface Area:

$$\frac{1 \text{ square}}{8 \times 8 = 64}$$

4 triangles

$$A = \frac{1}{2} b \cdot h$$

$$A = \frac{1}{2} \cdot 8 \cdot 15$$

$$A = 60$$

$$60 \times 4 = 240$$

$$64 + 240 = 304 \text{ cm}^2$$

Volume:

$$V = \frac{1}{3} \cdot A \text{ of } B \cdot H$$

$$V = \frac{1}{3} \cdot 64 \cdot 14.5$$

$$V = 309.3 \text{ cm}^3$$

$$a^2 + b^2 = c^2$$

$$4^2 + b^2 = 15^2$$

$$16 + b^2 = 225$$

$$-16 \quad -16$$

$$\sqrt{b^2} = \sqrt{209}$$

$$b \approx 14.5$$

$$A = 8 \cdot 8$$

$$A = 64$$

g.

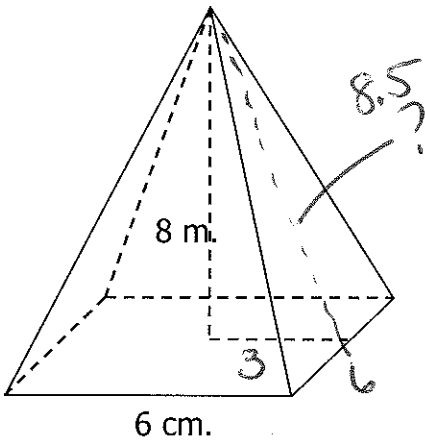

NAME: Square Pyramid

Surface Area:

$$\frac{1 \text{ square}}{6 \times 6 = 36}$$

4 triangles

$$A = \frac{1}{2} \cdot b \cdot h$$

$$A = \frac{1}{2} \cdot 6 \cdot 8.5$$

$$A = 25.5$$

$$25.5 \times 4 = 102$$

$$36 + 102 = 138 \text{ cm}^2$$

Volume:

$$V = \frac{1}{3} \cdot A \text{ of } B \cdot h$$

$$V = \frac{1}{3} \cdot 36 \cdot 8$$

$$V = 96 \text{ cm}^3$$

$$a^2 + b^2 = c^2$$

$$3^2 + 8^2 = c^2$$

$$9 + 64 = c^2$$

$$\sqrt{73} = \sqrt{c^2}$$

$$c \approx 8.5$$

Area

$$b \cdot b = 36$$

7. You are helping your dad to build a sandbox for you little brother. The sandbox is in the shape of a rectangular prism that is 5 feet wide, 6 feet long, and 1 foot tall. How much sand will you need to fill the sandbox?

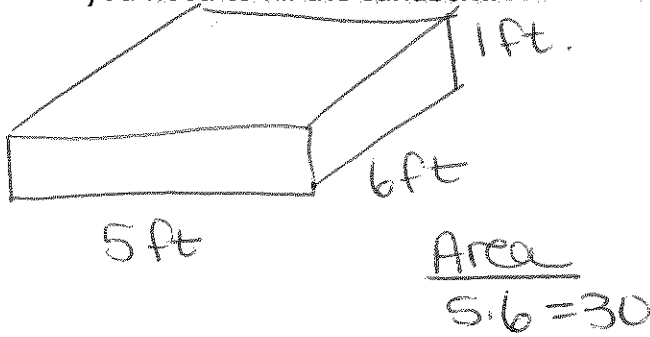

$$V = A \text{ of } B \times h$$

$$V = 30 \times 1$$

$$V = 30 \text{ ft}^3$$

8. You work for a cereal company and are designing a new cereal box. The box measures 12 inches wide, 18 inches tall, and 3 inches deep.

- a. How much cardboard will you need to make each cereal box.

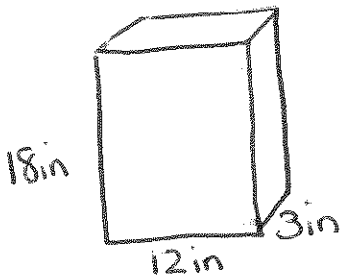

$$\frac{T+B}{12 \cdot 3 = 36}$$

$$36 \times 2 = 72$$

$$\frac{L+R}{18 \times 3 = 54}$$

$$54 \times 2 = 108$$

$$\frac{F+B}{12 \times 18 = 216}$$

$$216 \times 2 = 432$$

$$72 + 108 + 432 = 612 \text{ in}^2$$

- b. How much cereal can you fit into your box?

Area

$$12 \cdot 3 = 36$$

$$V = A \text{ of } B \times h$$

$$V = 36 \times 18$$

$$V = 648 \text{ in}^3$$

9. A can has a radius of 3 cm and a height of 8 cm. Find the volume of the can in mL.

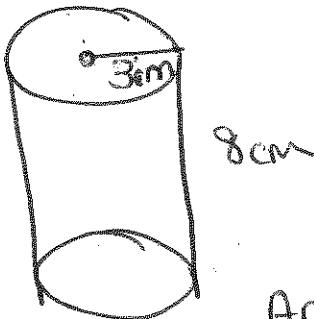

$$V = A \text{ of } B \times h$$

$$V = 28.26 \times 8$$

$$V = 226.1 \text{ cm}^3$$

or

Area

$$C = \pi r^2$$

$$C = \pi \cdot 3^2$$

$$C = 28.26$$