

# Final Exam Review Sheet

## Families of Functions

1<sup>st</sup> Front Page

1. List at least three other names for each of the following...

x-values

domain  
independent  
input  
control

y-values

range  
dependent  
output  
experimental

2. Give the coordinates for the points graphed on the grid below...

F( -3 , 4 )  
R( -1 , -5 )  
O( 3 , -1 )  
G( 6 , 5 )

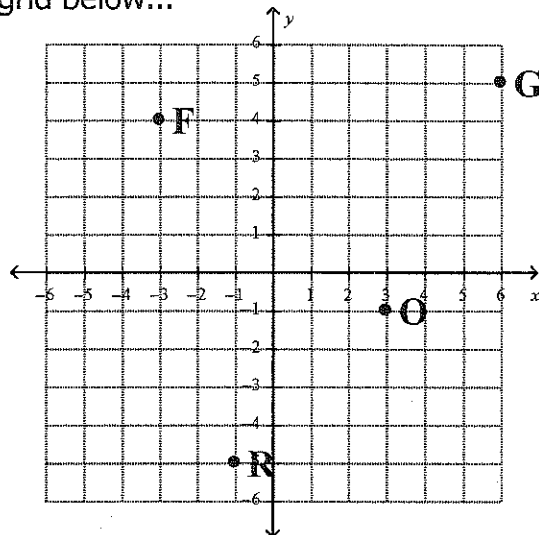

3. Mr. Cravotta is a busy man! He started out with a list of 3 students he needed to meet with today. Each hour that passes by, two students were added to his list. Use this situation to answer the following questions...

a. What is the independent variable?

time (hours)

b. What is the dependent variable?

# of students on the list.

c. Complete the table.

x	0	1	2	3	4	5	6
y	3	5	7	9	11	13	15

d. Is this a function? Why or why not?

Yes because each input (domain) is paired with exactly one output (range).

4. Nicole went to the mall with \$57. Every time she goes into the store, she spends \$9. Use this situation to answer the following questions.

a. What is the independent variable?

# of stores

b. What is the dependent variable?

amount of money left

c. Complete the table.

x	0	1	2	3	4	5	6
y	57	48	39	30	21	12	3

d. Is this a function? Why or why not?

Yes because each domain value is paired with exactly one range value.

5. For each rule, complete the tables below. Show the calculations in the "work" box.

a.  $y = 3x - 12$

x	-2	-1	0	1	2
Work	$3(-2) - 12$ $-6 - 12$	$3(-1) - 12$ $-3 - 12$	$3(0) - 12$ $0 - 12$	$3(1) - 12$ $3 - 12$	$3(2) - 12$ $6 - 12$
y	-18	-15	-12	-9	-6

b.  $y = x^2 - 2x$

x	-2	-1	0	1	2
Work	$(-2)^2 - 2(-2)$ $4 + 4$	$(-1)^2 - 2(-1)$ $1 + 2$	$(0)^2 - 2(0)$ $0 - 0$	$(1)^2 - 2(1)$ $1 - 2$	$(2)^2 - 2(2)$ $4 - 4$
y	8	3	0	-1	0

1<sup>st</sup> Back Page

c.  $y = 3^x$

x	-2	-1	0	1	2
Work	$3^{-2}$ $\frac{1}{3^2}$	$3^{-1}$ $\frac{1}{3^1}$	$3^0$	$3^1$	$3^2$
y	$\frac{1}{9}$	$\frac{1}{3}$	1	3	9

6. Draw two graphs that are functions.

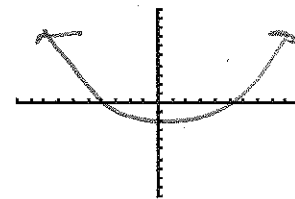
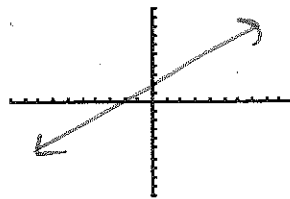

7. Draw two graphs that are NOT functions.

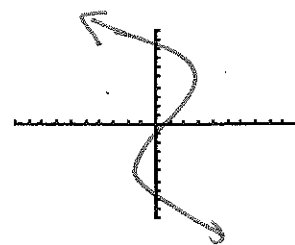
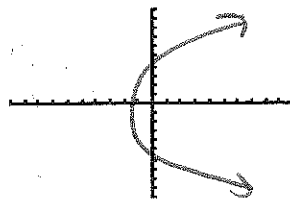

8. For each of the graphs below, decide if they are a function or not. Justify your answer. If they are a function tell which of the families of functions it belongs to.

a.

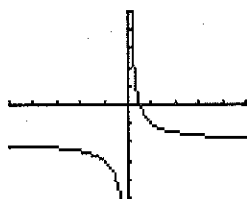

Function: Yes or No

Why It passes the VLT

\_\_\_\_\_

Family: Rational/Inverse

b.

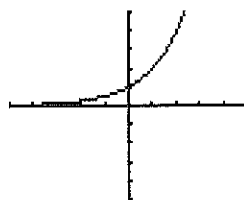

Function: Yes or No

Why It passes the VLT

\_\_\_\_\_

Family: exponential

c.

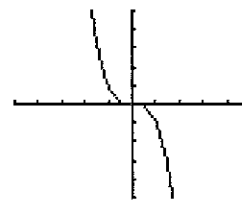

Function: Yes or No

Why It passes the VLT

\_\_\_\_\_

Family: Cubic

d.

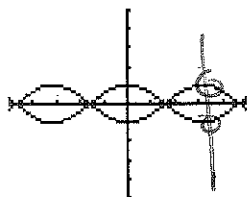

Function: Yes or No

Why It doesn't pass the VLT

\_\_\_\_\_

Family: \_\_\_\_\_

e.

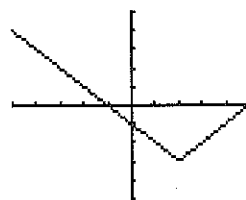

Function: Yes or No

Why It passes the VLT

\_\_\_\_\_

Family: Absolute Value

f.

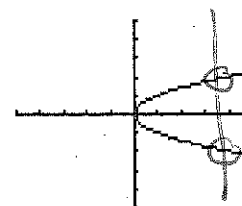

Function: Yes or No







Why It doesn't pass the VLT

\_\_\_\_\_

Family: \_\_\_\_\_

9. Fill in the table below.

2<sup>nd</sup> Back Page

Family Name	Shape of the Graph (sketch)	Properties of the Equation	Example Equations
Linear		$y = mx + b$ form	$y = 2x - 8$
Quadratic		x has to be squared	$x^2 + 3x$
Cubic		x has to be cubed	$4x^3 - 7$
Rational		has to have a # divided by x.	$\frac{12}{x}$
Exponential		x is the exponent	$3^x$
Absolute Value		x has to be inside the absolute value signs	$ 2x $
Roots		x has to be underneath the radical symbol	$\sqrt{3+x}$

10. Consider the situation described below... 3<sup>rd</sup> Front Page

*A bus is driving at a steady pace down the road. The bus then slows down and comes to a stop while the first student climbs aboard. The bus then speeds up and then continues driving at a steady pace. The bus then speeds up again as the speed limit for the road increases and then continues driving at this faster speed. The bus then slows down and comes to a stop while the next student climbs aboard.*

Sketch a graph showing the speed of the bus as it drives down the road.

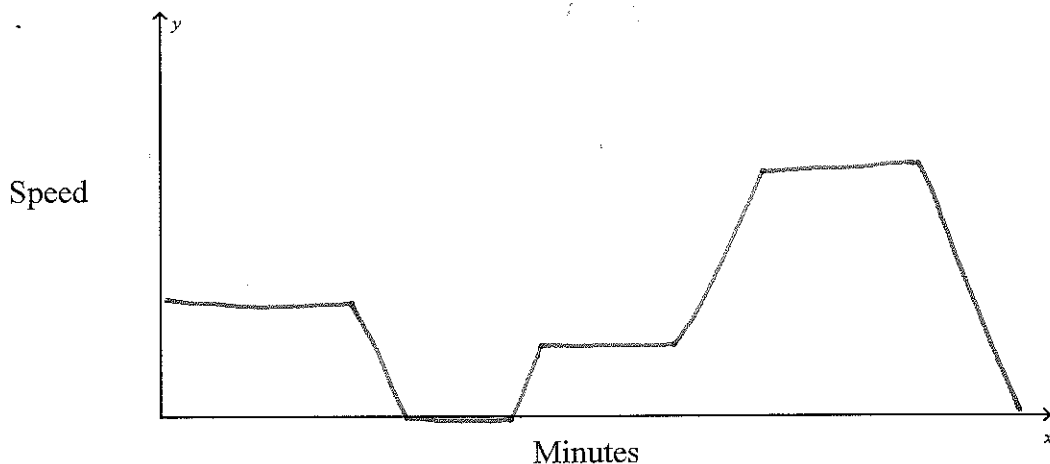

11. Consider the graph below. It illustrates the attendance at a museum over a period of days.

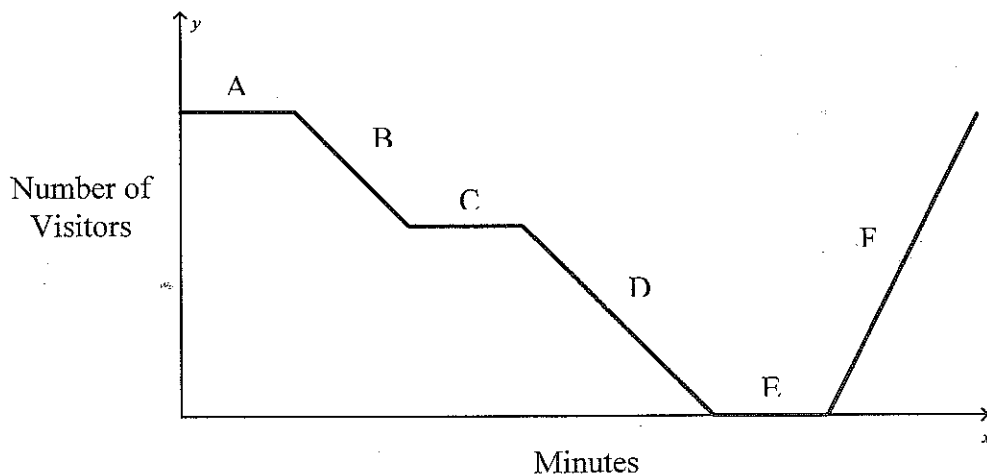

Describe what is happening during each part of the graph.

- A The attendance is high & is constant
- B The attendance decreases
- C The attendance is constant.
- D The attendance decreases.
- E No one is at the museum.
- F The attendance increases.

# Pythagorean Theorem and Distance Formula

12. Pythagorean theorem only works for right triangles.

13. The Pythagorean theorem states that  $a^2 + b^2 = c^2$ .

14. Which of the sides on the figure below is the "hypotenuse"? How can you tell?

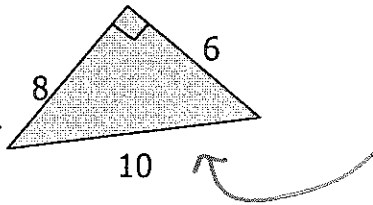

10 because it is across from the right angle and it is the longest side.

15. Find the missing side length,  $x$ , in each figure below...

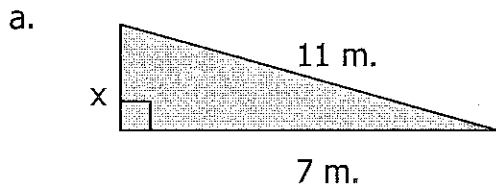

$$x^2 + 7^2 = 11^2$$

$$x^2 + 49 = 121$$

$$\begin{array}{r} -49 \\ -49 \end{array}$$

$$\sqrt{x^2} = \sqrt{72}$$

$$x \approx 8.5 \text{ m}$$

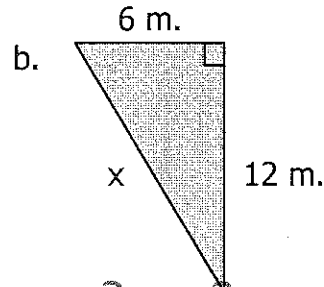

$$6^2 + 12^2 = x^2$$

$$36 + 144 = x^2$$

$$\sqrt{180} = \sqrt{x^2}$$

$$x \approx 13.4 \text{ m}$$

16. For each of the following groups of side lengths, determine whether or not they would form a right triangle. Be sure to explain your answer or show work to demonstrate your reasoning.

a. 15 ft., 9 ft., 12 ft.

$$9^2 + 12^2 = 15^2$$

$$81 + 144 = 225$$

$$225 = 225$$

Yes

b. 2 in., 7 in., 6 in.

$$2^2 + 6^2 = 7^2$$

$$4 + 36 = 49$$

$$40 \neq 49$$

No

17. A car drives due south for 120 miles, then turns and drive due east for 200 more miles. If a plane traveled this same distance, but could fly in a straight line from the 1<sup>st</sup> destination to the 2<sup>nd</sup>, how many miles would the plane be traveling?



$$120^2 + 200^2 = x^2$$

$$14,400 + 40,000 = x^2$$

$$\sqrt{54,400} = \sqrt{x^2}$$

$$x \approx 233.2 \text{ miles}$$

18. Find the perimeter of each figure below... 4<sup>th</sup> Front Page

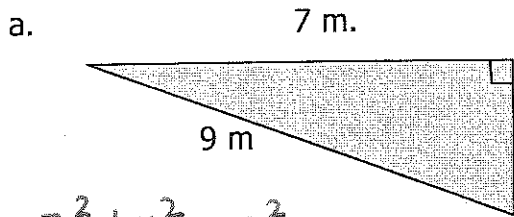

$$7^2 + x^2 = 9^2$$

$$49 + x^2 = 81$$

$$-49 \quad -49$$

$$\sqrt{x^2} = \sqrt{32}$$

$$x \approx 5.7 \text{ m}$$

$$7 + 5.7 + 9 = 21.7 \text{ m}$$

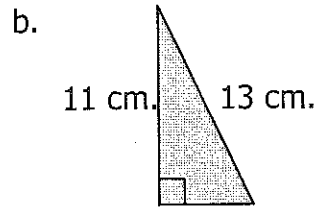

$$11^2 + x^2 = 13^2$$

$$121 + x^2 = 169$$

$$-121 \quad -121$$

$$\sqrt{x^2} = \sqrt{48}$$

$$x \approx 6.9$$

$$11 + 6.9 + 13 = 30.9 \text{ cm}$$

19. Find the area of each figure below... (Note: Area of a Triangle =  $\frac{1}{2} \times \text{base} \times \text{height}$ )

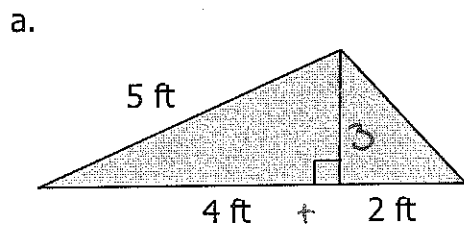

$$4^2 + x^2 = 5^2$$

$$16 + x^2 = 25$$

$$-16 \quad -16$$

$$\sqrt{x^2} = \sqrt{9}$$

$$x \approx 3$$

$$A = \frac{1}{2} \cdot 6 \cdot 3$$

$$A = 9 \text{ ft}^2$$

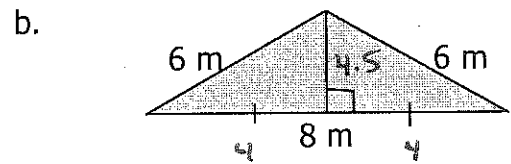

$$4^2 + x^2 = 6^2$$

$$16 + x^2 = 36$$

$$-16 \quad -16$$

$$\sqrt{x^2} = \sqrt{20}$$

$$x \approx 4.5$$

$$A = \frac{1}{2} \cdot 8 \cdot 4.5$$

$$A = 18 \text{ m}^2$$

20. The distance between two points can be found by using the following formula...

$$d = \sqrt{(x_2 - x_1)^2 + (y_2 - y_1)^2}$$

Use this formula to find the distance between each of the following pairs of points.

a. (1, 8) and (2, 13)

$$d = \sqrt{(2-1)^2 + (13-8)^2}$$

$$d = \sqrt{(1)^2 + (5)^2}$$

$$d = \sqrt{1 + 25}$$

$$d = \sqrt{26} \approx 5.1 \text{ units}$$

b. (-4, 7) and (6, -9)

$$d = \sqrt{(6 - (-4))^2 + (-9 - 7)^2}$$

$$d = \sqrt{(10)^2 + (-16)^2}$$

$$d = \sqrt{100 + 256} = \sqrt{356} \approx 18.9 \text{ units}$$

21. Find the distance between points A and B on the grid.

$$1^2 + 10^2 = x^2$$

$$1 + 100 = x^2$$

$$\sqrt{101} = \sqrt{x^2}$$

$$x \approx 10 \text{ units}$$

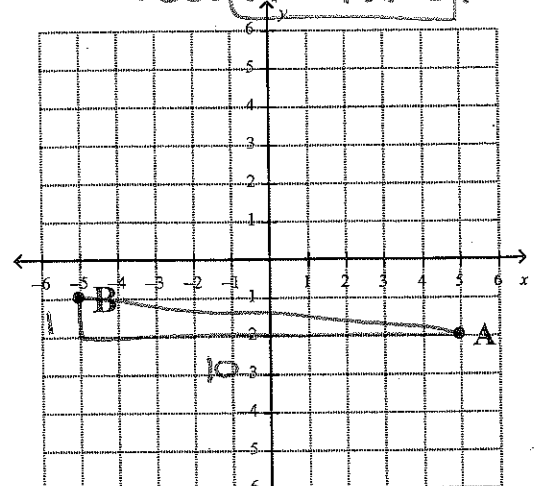

# Angle Relationships

22. Find x and then y in each figure below.

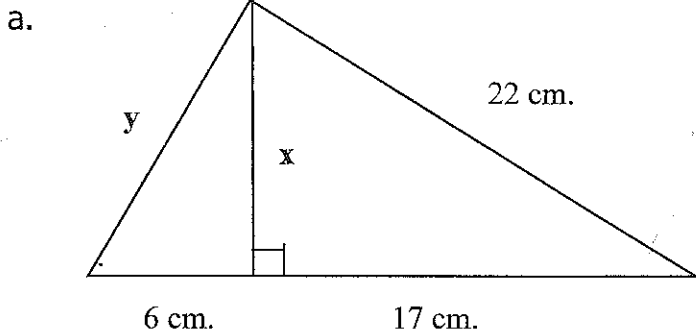

Find x.

$$x^2 + 17^2 = 22^2$$

$$x^2 + 289 = 484$$

$$-289 \quad -289$$

$$\sqrt{x^2} = \sqrt{195}$$

$$x \approx 14 \text{ cm}$$

Find y.

$$6^2 + 14^2 = y^2$$

$$36 + 196 = y^2$$

$$\sqrt{232} = \sqrt{y^2}$$

$$y \approx 15.2 \text{ cm}$$

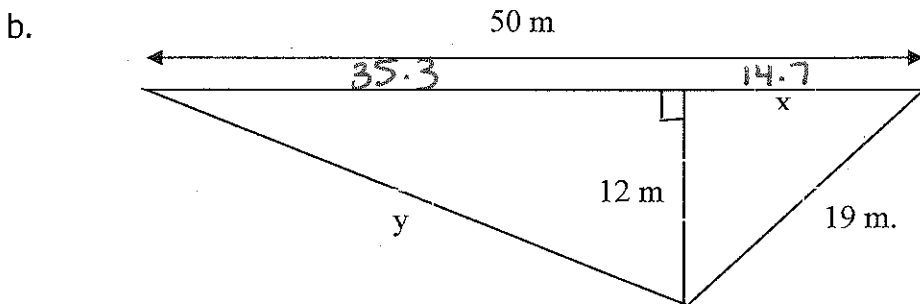

$$50.0$$

$$-14.7$$

$$\hline 35.3$$

Find x.

$$x^2 + 12^2 = 19^2$$

$$x^2 + 144 = 361$$

$$-144 \quad -144$$

$$\sqrt{x^2} = \sqrt{217}$$

$$x \approx 14.7 \text{ m}$$

Find y.

$$35.3^2 + 12^2 = y^2$$

$$1246.09 + 144 = y^2$$

$$\sqrt{1390.09} = \sqrt{y^2}$$

$$y \approx 37.3 \text{ m}$$

23. Paul has a box that has dimensions 16 in. by 5 in. by 4 in. What is the longest possible length that an object could be that would fit inside the box?

Find x.

$$16^2 + 4^2 = c^2$$

$$256 + 16 = c^2$$

$$\sqrt{272} = \sqrt{c^2}$$

$$c \approx 16.5$$

Find y.

$$16.5^2 + 5^2 = c^2$$

$$272.25 + 25 = c^2$$

$$\sqrt{297.25} = \sqrt{c^2}$$

$$c \approx 17.2 \text{ in}$$

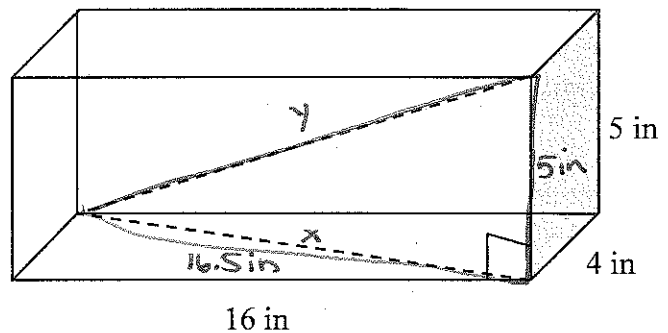



24. Use the drawing to the right.

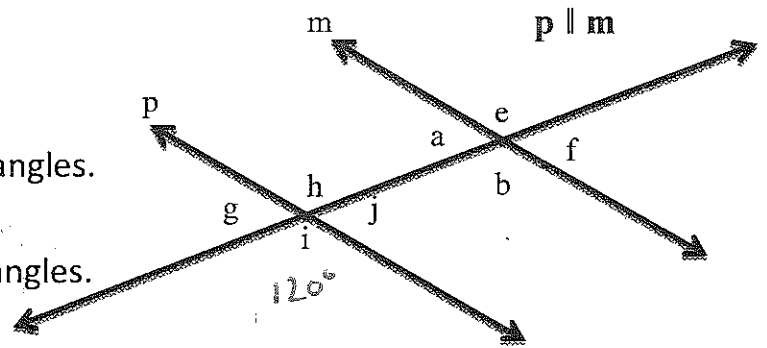

a. Name two pairs of same-side interior angles.

$h + a, j + b$

b. Name two pairs of alternate-interior angles.

$a + j, h + b$

c. Name four pairs of corresponding angles.

$g + a, h + c, i + b, j + f$

d. Name four pairs of vertical angles.

$h + i, g + j, a + c, e + b$

e. Name two pairs of supplementary angles that are NOT same side interior.

$i + j, h + j$

f. Suppose  $m\angle i = 120^\circ$ , find  $m\angle h = 120^\circ$        $m\angle b = 120^\circ$        $m\angle a = 60^\circ$        $m\angle j = 60^\circ$

g. Suppose that  $m\angle h = 3x + 12$  and  $m\angle a = 4x - 7$ . Find  $m\angle h$  and  $m\angle a$ .

Supplementary  
 $3x + 12 + 4x - 7 = 180$   
 $7x + 5 = 180$   
 $7x = 175$   
 $x = 25$

$\angle h$   
 $3x + 12$   
 $3(25) + 12$   
 $75 + 12$   
 $87^\circ$

$\angle a$   
 $4x - 7$   
 $4(25) - 7$   
 $100 - 7$   
 $93^\circ$

h. Suppose that  $m\angle g = 5x - 31$  and  $m\angle f = 4x - 10$ . Find  $m\angle g$  and  $m\angle f$ .

Congruent  
 $5x - 31 = 4x - 10$   
 $x = 21$   
 $x = 21$

$\angle g$   
 $5(21) - 31$   
 $105 - 31$   
 $74^\circ$

$\angle f$   
 $4(21) - 10$   
 $84 - 10$   
 $74^\circ$

25. Find the value of x and y.

5<sup>th</sup> Back Page

a.

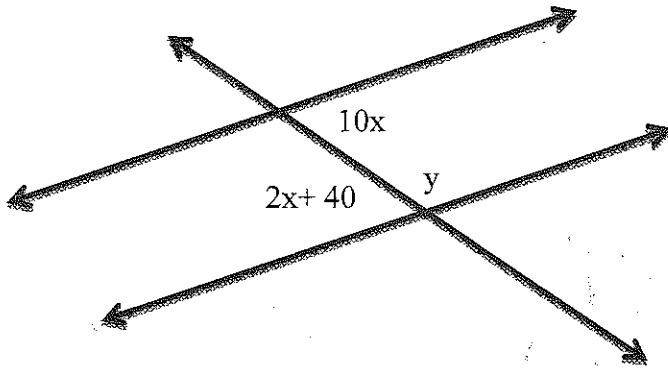

Find x

$$10x = 2x + 40$$

$$-2x \quad -2x$$

$$\frac{8x}{8} = \frac{40}{8}$$

$$x = 5$$

$$x = \underline{5}$$

$$y = \underline{130^\circ}$$

Find y

$$10(5) = 50$$

$$180 - 50 = 130^\circ$$

b.

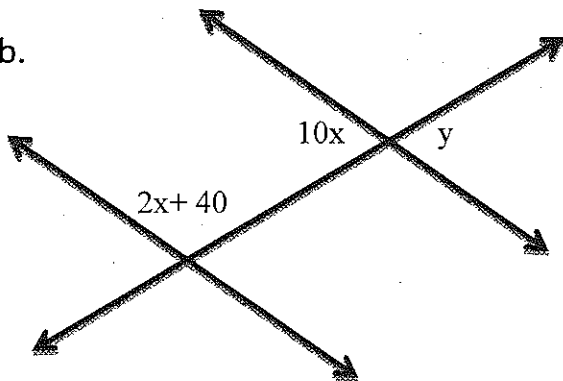

Find x

$$10x + 2x + 40 = 180$$

$$12x + 40 = 180$$

$$-40 \quad -40$$

$$12x = 140$$

$$\frac{12x}{12} = \frac{140}{12} \quad x = 11.\bar{6}$$

Find y.

$$10 \cdot 11.\bar{6} = 116.\bar{6}$$

$$x = \underline{11.\bar{6}}$$

$$y = \underline{116.\bar{6}}$$

26. Find all the angle measures in each triangle below.

a.

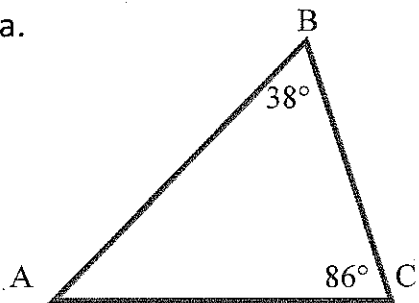

$$\begin{array}{r} 38 \\ + 86 \\ \hline 124 \end{array}$$

$$\angle A = \underline{56^\circ}$$

$$\angle B = \underline{38^\circ}$$

$$\angle C = \underline{86^\circ}$$

$$\begin{array}{r} 180 \\ - 124 \\ \hline 56 \end{array}$$

b.

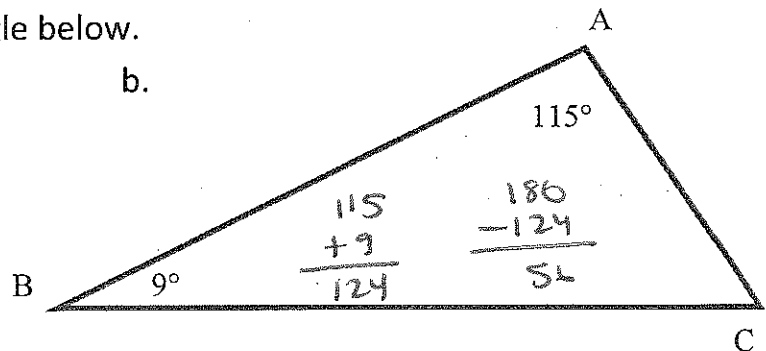

$$\begin{array}{r} 115 \\ + 9 \\ \hline 124 \end{array}$$

$$\begin{array}{r} 180 \\ - 124 \\ \hline 56 \end{array}$$

$$\angle A = \underline{115^\circ}$$

$$\angle B = \underline{9^\circ}$$

$$\angle C = \underline{56^\circ}$$

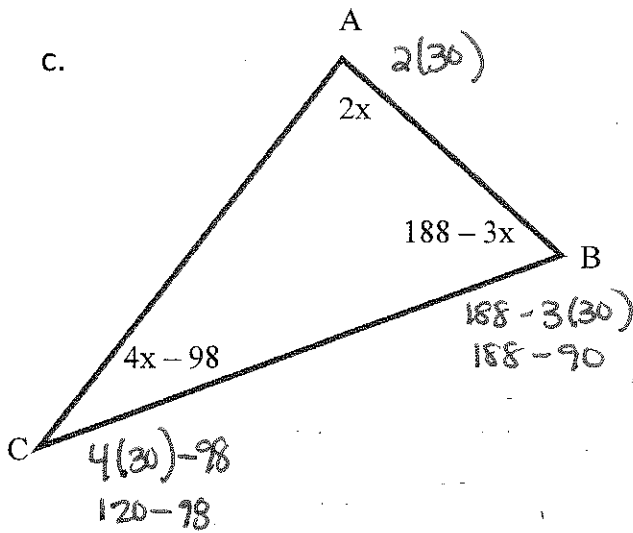

$$2x + 188 - 3x + 4x - 98 = 180$$

$$3x + 90 = 180$$

$$\begin{array}{r} -90 \\ -90 \end{array}$$

$$\frac{3x}{3} = \frac{90}{3}$$

$$x = 30$$

$$\angle A = \underline{60^\circ}$$

$$\angle B = \underline{98^\circ}$$

$$\angle C = \underline{22^\circ}$$

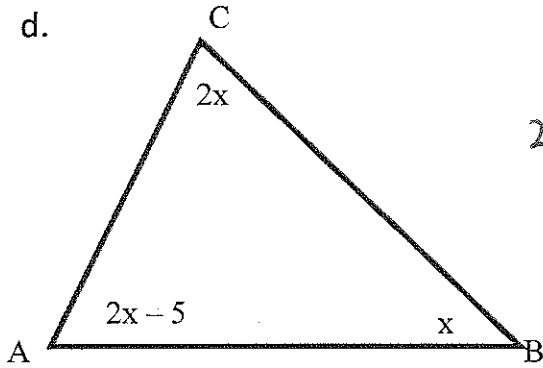

$$2x + x + 2x - 5 = 180$$

$$5x - 5 = 180$$

$$\begin{array}{r} +5 \\ +5 \end{array}$$

$$\frac{5x}{5} = \frac{185}{5}$$

$$x = 37$$

$$\angle A = \underline{69^\circ}$$

$$\angle B = \underline{37^\circ}$$

$$\angle C = \underline{74^\circ}$$

$$\frac{\angle A}{2(37) - 5}$$

$$69^\circ$$

$$\frac{\angle C}{2(37)}$$

$$74^\circ$$

27. Find the measure of each of the angle below...

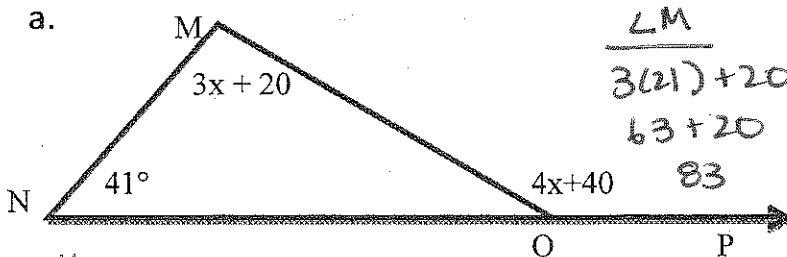

$$41 + 3x + 20 = 4x + 40$$

$$3x + 61 = 4x + 40$$

$$\begin{array}{r} -3x \\ -3x \end{array}$$

$$61 = 1x + 40$$

$$\begin{array}{r} -40 \\ -40 \end{array}$$

$$21 = x$$

$$\frac{\angle M}{3(21) + 20}$$

$$63 + 20$$

$$83$$

$$\angle M = \underline{83^\circ}$$

$$\angle N = \underline{41^\circ}$$

$$\frac{\angle MON}{83 + 41 + x = 180}$$

$$124 + x = 180$$

$$\begin{array}{r} -124 \\ -124 \end{array}$$

$$x = 56$$

$$\frac{\angle MOP}{4(21) + 40}$$

$$84 + 40$$

$$124$$

$$\angle MON = \underline{56^\circ}$$

$$\angle MOP = \underline{124^\circ}$$

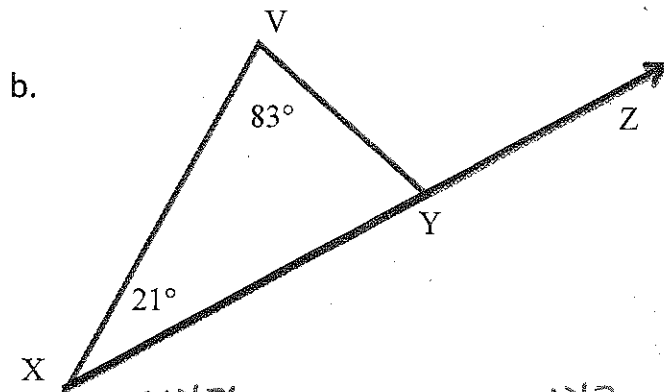

$$\begin{array}{l} \angle VYX \\ \hline 83 + 21 + x = 180 \\ 104 + x = 180 \\ -104 \quad -104 \\ \hline x = 76 \end{array}$$

$$\begin{array}{l} \angle VYZ \\ \hline 83 + 21 = 104^\circ \end{array}$$

$$\angle X = \underline{76^\circ}$$

$$\angle V = \underline{83^\circ}$$

$$\angle VYX = \underline{21^\circ}$$

$$\angle VYZ = \underline{104^\circ}$$

28. Which of the following words means the same size and same shape?

- a. Similar      b. compare      c. congruent      d. translate

29. Describe in words each of our rules for:

- Rotating  $90^\circ$  x and y switch locations + y changes to its opposite
- Reflecting over the x-axis. x stays the same and y changes to its opposite
- Translating right 3 units and then down 2 units.  
add 3 to the x coordinate + subtract 2 from y.

30. When you rotate a figure it gets bigger.

TRUE or FALSE

Justify: Rotating a figure changes its orientation, not its size or shape.

31. Explain the difference between a "pre-image" and an "image".

The pre-image is the original + the image is the result after the transformation.

32. Complete the following transformations for each shape, by completing the following...

- Identify the pre-image coordinates.
- Find the image coordinates.
- Draw the new shape and label the vertices. (A' or x'...)

7<sup>th</sup> Front Page

a. Translate 4 units DOWN.

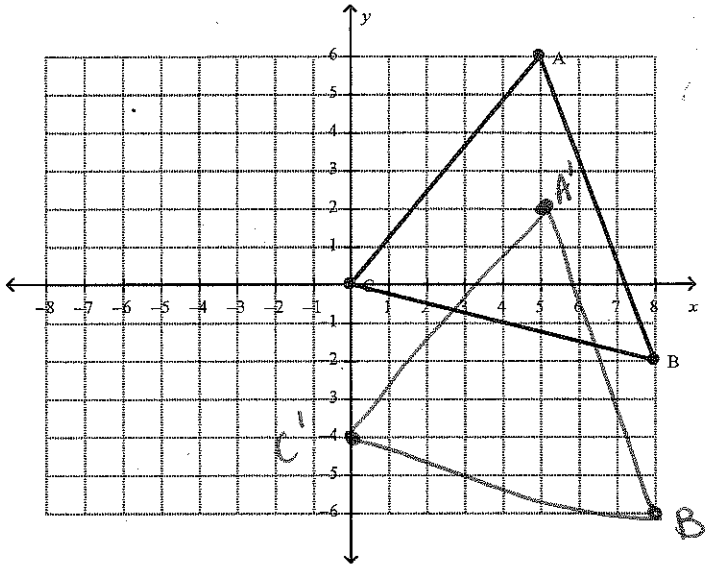

A (5, 6)      A' (5, 2)  
 B (8, -2)      B' (8, -6)  
 C (0, 0)      C' (0, -4)  
 Rule:  $(x, y) \rightarrow (x, y - 4)$

b. Reflect over the y-axis.

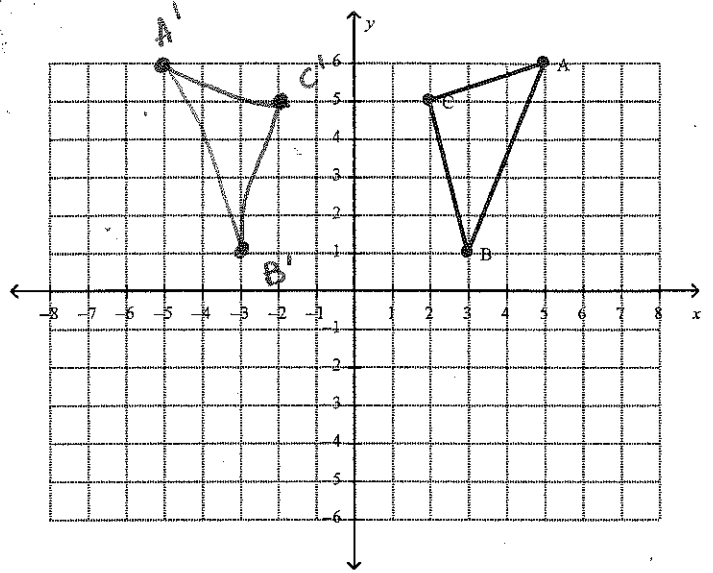

A (5, 6)      A' (-5, 6)  
 B (3, 1)      B' (-3, 1)  
 C (2, 5)      C' (-2, 5)  
 Rule:  $(x, y) \rightarrow (-x, y)$

c. Rotate 270 degrees CC

7<sup>th</sup> Back Page

d. Translate 1 unit left and 5 units up

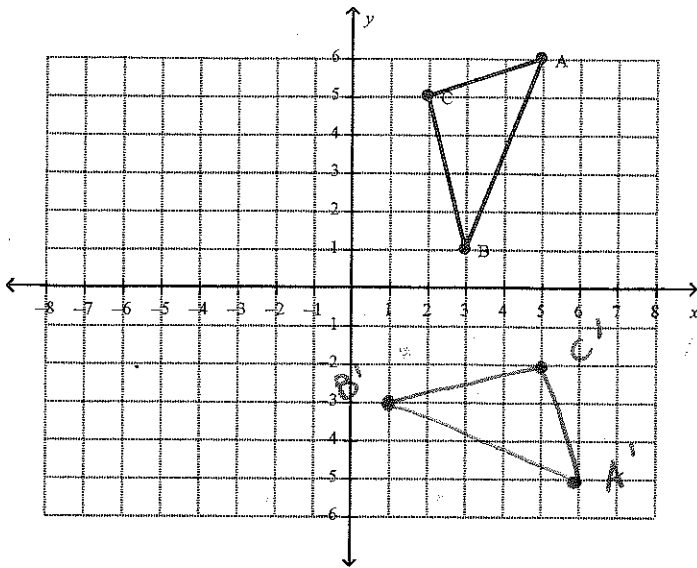

A (5,6)      A' (6,-5)  
 B (3,1)      B' (-3,-2)  
 C (2,5)      C' (5,-2)  
 Rule:  $(x,y) \rightarrow (y,-x)$

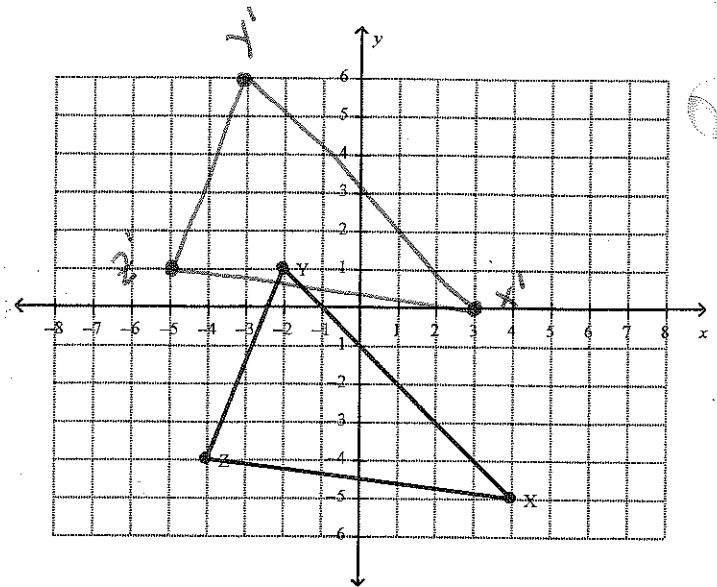

X (4,-5)      X' (3,0)  
 Y (-2,1)      Y' (-3,6)  
 Z (-4,-4)      Z' (-5,1)  
 Rule:  $(x,y) \rightarrow (x-1, y+5)$

a. Rotate 180°

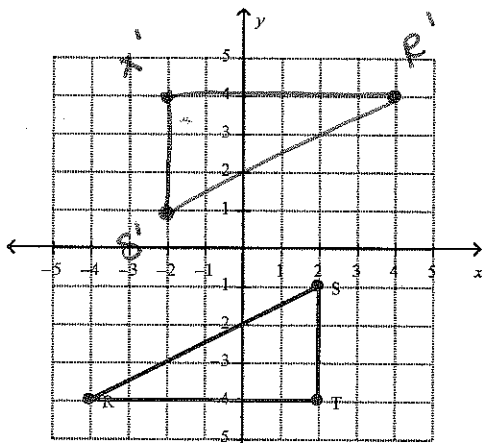

R (-4,-4)      R' (4,4)  
 S (2,-1)      S' (-2,1)  
 T (2,-4)      T' (-2,4)  
 Rule:  $(x,y) \rightarrow (-x,-y)$

f. Reflect over the x-axis

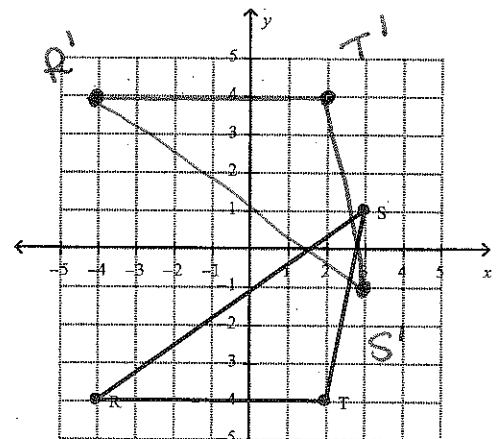

R (-4,-4)      R' (-4,4)  
 S (2,-1)      S' (2,1)  
 T (2,-4)      T' (2,4)  
 Rule:  $(x,y) \rightarrow (x,-y)$

g. Translate 2 units right and 3 units up

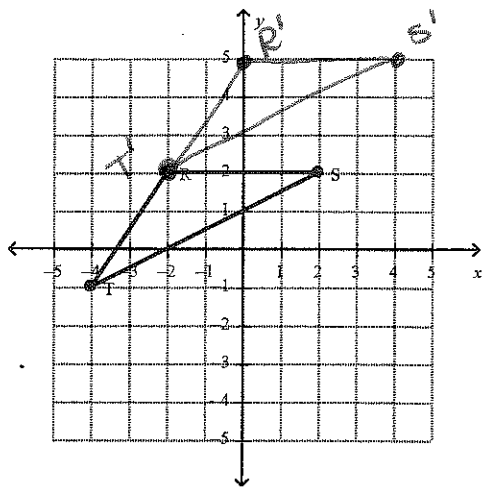

8<sup>th</sup> Front Page

h. Reflect over the y-axis.

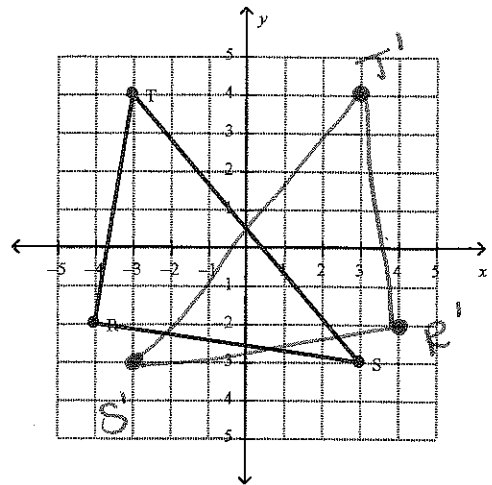

R  $(-2, 2)$       R'  $(0, 5)$   
 S  $(2, 2)$       S'  $(4, 5)$   
 T  $(-4, -1)$       T'  $(-2, 2)$   
 Rule:  $(x, y) \rightarrow (x+2, y+3)$

R  $(-4, -2)$       R'  $(4, -2)$   
 S  $(3, -3)$       S'  $(-3, -3)$   
 T  $(-3, 4)$       T'  $(3, 4)$   
 Rule:  $(x, y) \rightarrow (-x, y)$

33. Draw all lines of symmetry for the following figures.

a.



b.



c.

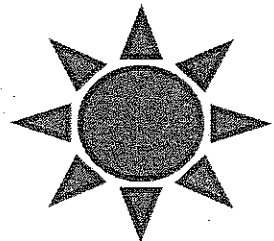

34. For each of the following pairs of points, identify the transformation. Was it a rotation (how much), was it a reflection (over which line), was it a translation (which way and how much)?

	Pre-Image	Image	Transformation
a.	(6, 8)	(8, -6)	Rotation $270^\circ$ counterclockwise
b.	(-20, -3)	(-25, 0)	Translate left 5 and up 3
c.	(-7, 100)	(-100, -7)	Rotation $90^\circ$ counterclockwise
d.	(3, -12)	(3, 12)	Reflect over the x-axis
e.	(0, 0)	(-6, 15)	Translate left 6 and up 15
f.	(14, -62)	(62, 14)	Rotation $90^\circ$ counterclockwise

35. Fill in the missing image points. 8<sup>th</sup> Back Page

	Pre-Image	Transformation	Image
a.	(6,8)	Translate right 7 and down 12.	(13, -4)
b.	(-20, -3)	Rotate 270° CC	(-3, 20)
c.	(-7, 100)	Reflection over the x-axis.	(-7, -100)
d.	(3, -12)	Rotate 180°	(-3, 12)
e.	(0,0)	Translate 4 left.	(-4, 0)
f.	(14, -62)	Reflection over the y-axis.	(-14, -62)

36. Find the scale factor of the dilation pictured below.

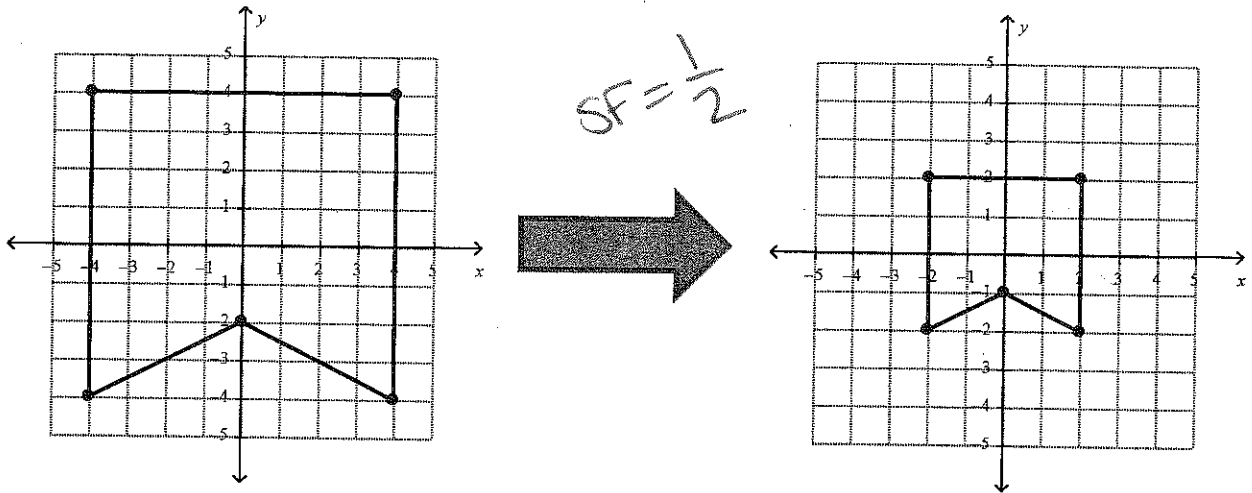

37. Consider the pre-image on the graph and the information below. Draw in the image and fill in the pre-image and the image coordinates.

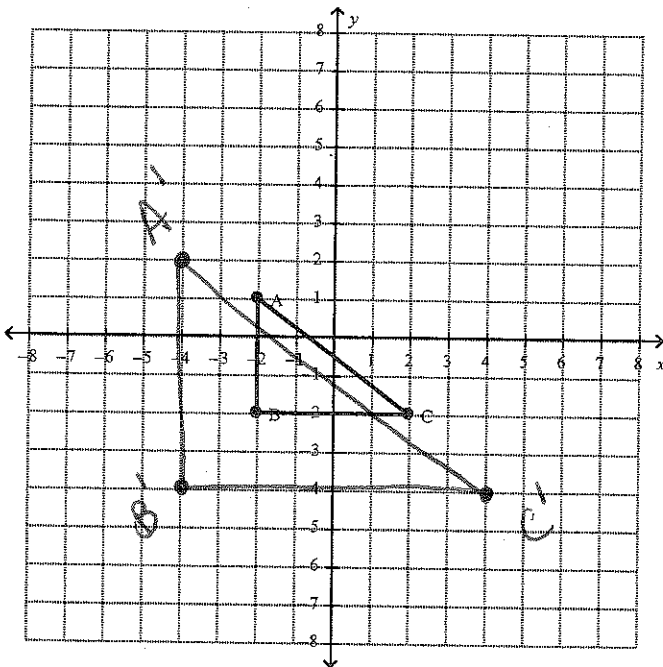

Center of Dilation (0, 0)

Scale Factor = 2

Pre-Image

A (-2, 1)

B (-2, -2)

C (2, 2)

Rule:  $(x, y) \rightarrow (2x, 2y)$

Image

A' (-4, 2)

B' (-4, -4)

C' (4, -4)



38. Describe the sequence of transformations illustrated in each graph below.

a.

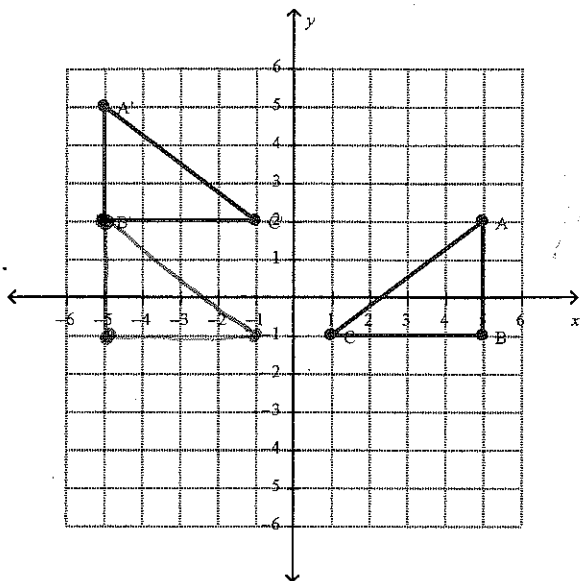

- 1) Reflect over the y axis
- 2) Translate up 3

b.

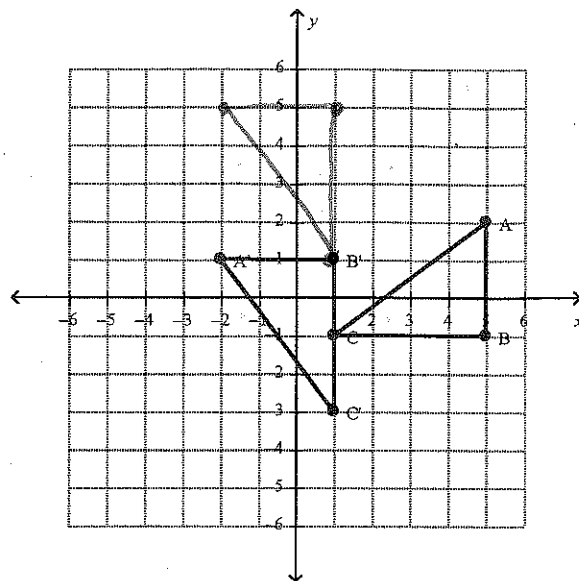

- 1) Rotate 90° counterclockwise
- 2) Translate down 4

c.

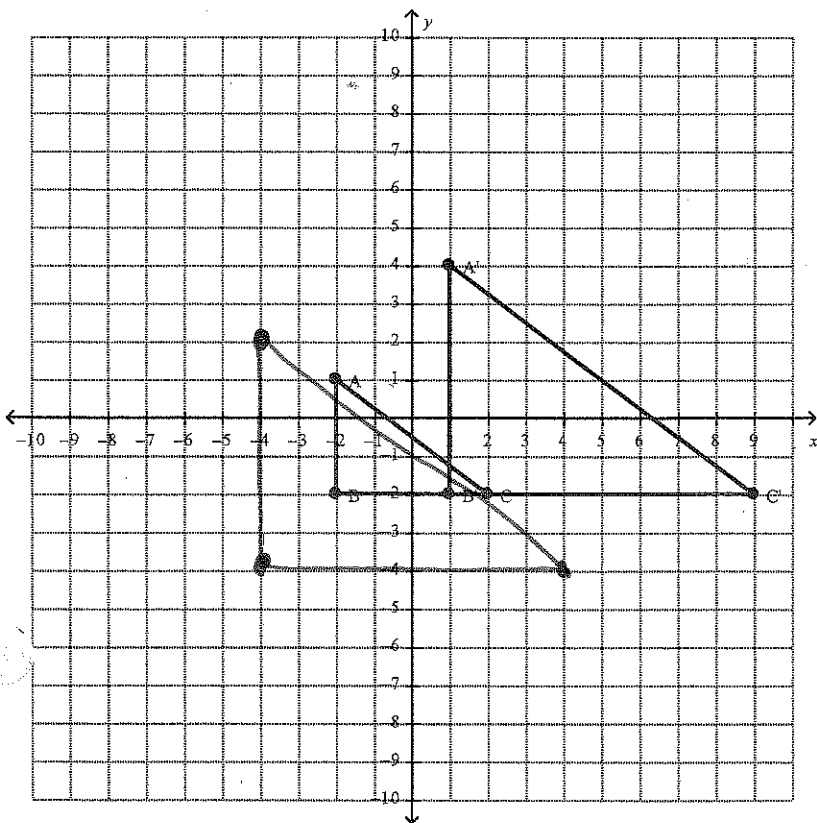

- 1) Dilate by SF=2
- 2) Translate right 5
- 3) up 2

d.

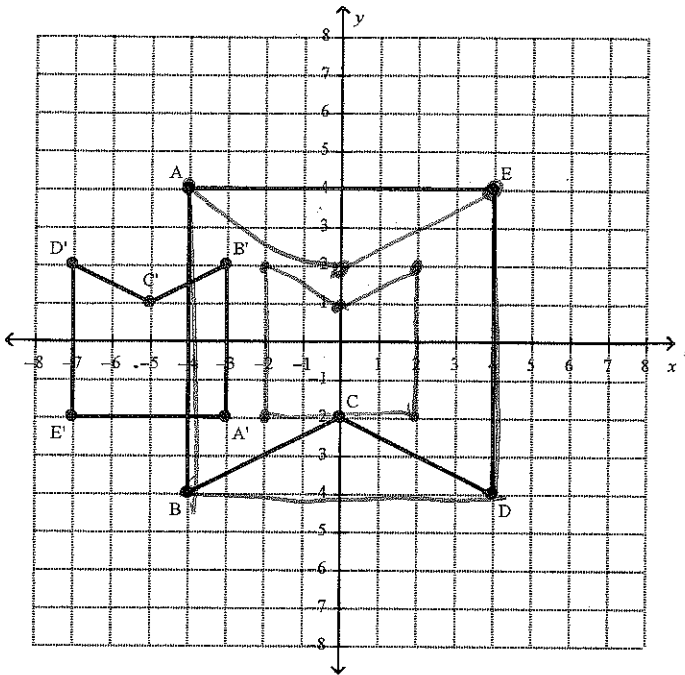

1) Reflect over the x-axis

2) Dilate by a SF of 1/2

3) Translate left 5.

## Surface Area, and Volume

39. Explain what *surface area* of an object describes.

Surface area is the space on the outside of an object.

40. Explain what *volume* of an object describes.

Volume is the amount of space on the inside of a 3-dimensional object.

41. When finding the surface area of a cone, which height do you use?

Vertical Height or Slant Height

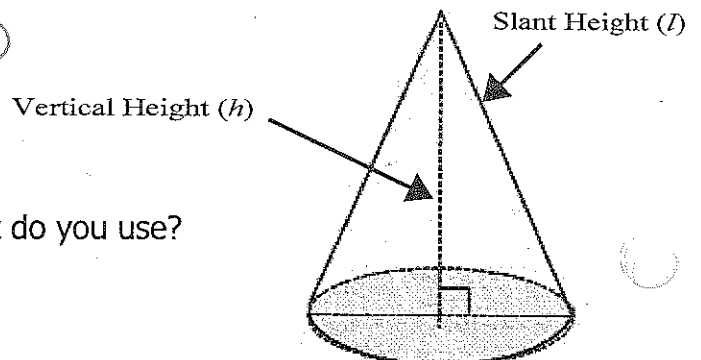

42. When finding the volume of a cone, which height do you use?

Vertical Height or Slant Height

43. For each of the following: Name the figure, find the Surface Area, and find the Volume. Show all of your work.

a.

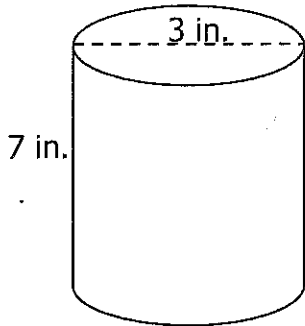

NAME: Cylinder

Surface Area: (Formula:  $2\pi r^2 + 2\pi r h$ )  
 $2\pi \cdot 1.5^2 + 2\pi \cdot 1.5 \cdot 7$   
 $14.13 + 65.94 \approx 80.1 \text{ in}^2$

Volume: (Formula:  $V = A_{\text{of B}} \cdot h$ )

$\pi r^2$   
 $\pi \cdot 1.5^2$   
 $7.065$   
 $7.065 \cdot 7 = 49.5 \text{ in}^3$

b.

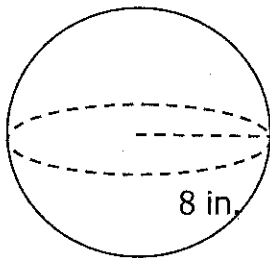

NAME: Sphere

Surface Area: (Formula:  $4\pi r^2$ )  
 $4\pi \cdot 8^2$   
 $\approx 803.8 \text{ in}^2$

Volume: (Formula:  $\frac{4}{3}\pi r^3$ )

$\frac{4}{3}\pi \cdot 8 \cdot 8 \cdot 8$   
 $\approx 2143.6 \text{ in}^3$

c.

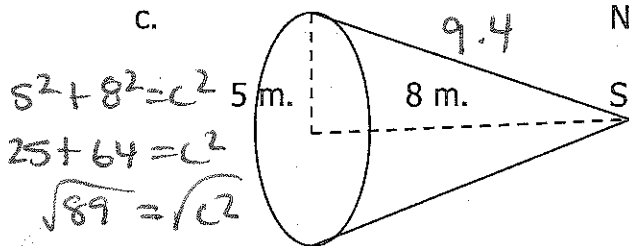

NAME: Cone

Surface Area: (Formula:  $\pi r^2 + \pi r l$ )  
 $\pi \cdot 5^2 + \pi \cdot 5 \cdot 9.4$   
 $78.5 + 147.58 = 226.1 \text{ m}^2$

Volume: (Formula:  $\frac{1}{3} A_{\text{of B}} \cdot h$ )

$\frac{1}{3} \cdot 78.5 \cdot 8$   
 $\approx 209.3 \text{ m}^3$

$\pi \cdot 5^2$   
 $78.5$

$5^2 + 8^2 = c^2$   
 $25 + 64 = c^2$   
 $\sqrt{89} = \sqrt{c^2}$   
 $c \approx 9.4$

d.

$$a^2 + b^2 = c^2$$

$$20^2 + b^2 = 30^2$$

$$400 + b^2 = 900$$

$$-400 \quad -400$$

$$\sqrt{b^2} = \sqrt{500}$$

$$b \approx 22.4$$

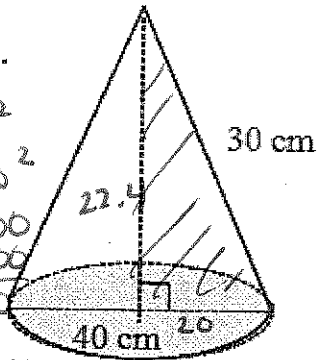

Diagram not to scale

$$\pi \cdot 20^2$$

$$1256$$

NAME: Cone

Surface Area: (Formula:  $\pi r^2 + \pi r l$ )

$$\pi \cdot 20^2 + \pi \cdot 20 \cdot 30$$

$$1256 + 1884 = \boxed{3140 \text{ cm}^2}$$

Volume: (Formula:  $\frac{1}{3} A_{\text{of B}} \cdot h$ )

$$\frac{1}{3} \cdot 1256 \cdot 22.4$$

$$\boxed{9378.1 \text{ cm}^3}$$

e.

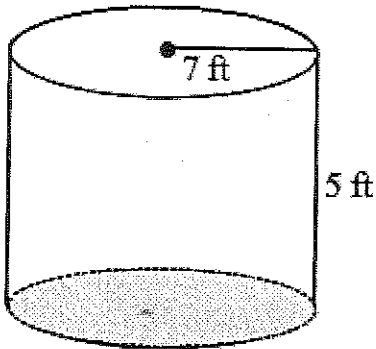

$$\pi r^2$$

$$\pi \cdot 7^2 = 153.86$$

NAME: Cylinder

Surface Area: (Formula:  $2\pi r^2 + 2\pi r h$ )

$$2\pi \cdot 7^2 + 2\pi \cdot 7 \cdot 5$$

$$307.72 + 219.8$$

$$\approx \boxed{527.5 \text{ ft}^2}$$

Volume: (Formula:  $A_{\text{of B}} \times h$ )

$$153.86 \times 5 = \boxed{769.3 \text{ ft}^3}$$

f.

$$4^2 + h^2 = 15^2$$

$$16 + h^2 = 225$$

$$-16 \quad -16$$

$$\sqrt{h^2} = \sqrt{209}$$

$$h \approx 14.5$$

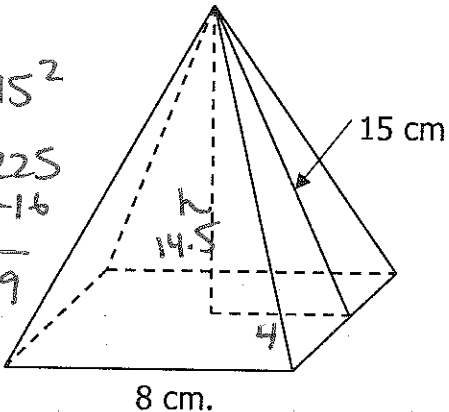

$$8 \cdot 8 = 64$$

NAME: Square pyramid

Surface Area: (Formula: \_\_\_\_\_)

<u>1 square</u>	<u>4 triangles</u>
$8 \cdot 8 = 64$	$\frac{1}{2} \cdot 8 \cdot 15 = 60$
	$\times 4$
	$\hline 240$
$64 + 240 = \boxed{304 \text{ cm}^2}$	

Volume: (Formula:  $\frac{1}{3} A_{\text{of B}} \cdot h$ )

$$\frac{1}{3} \cdot 64 \cdot 14.5 = \boxed{309.3 \text{ cm}^3}$$

g.

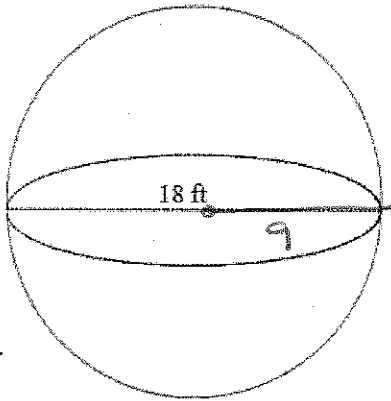
NAME: SphereSurface Area: (Formula:  $4\pi r^2$ )

$$4\pi \cdot 9^2 = \boxed{1017.4 \text{ ft}^2}$$

Volume: (Formula:  $\frac{4}{3}\pi r^3$ )

$$\frac{4}{3}\pi \cdot 9^3 = \boxed{3052.1 \text{ ft}^3}$$

44. You are helping your dad to build a sandbox for your little brother. The sandbox is in the shape of a cylinder that is 6 feet in diameter and 1 foot tall. How much sand will you need to fill the sandbox? Show you all of your work.

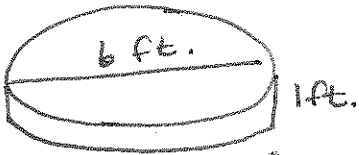

$$V = A \text{ of } B \cdot h$$

$$V = 28.26 \cdot 1$$

$$V \approx \boxed{28.3 \text{ ft}^3}$$

$$\begin{aligned} &\pi r^2 \\ &\pi \cdot 3^2 \\ &28.26 \end{aligned}$$

45. A can has a radius of 3 cm and a height of 8 cm. Find the volume. Show you all of your work.

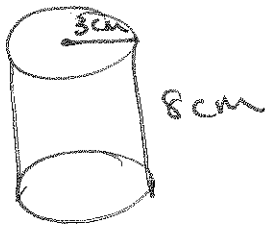

$$V = A \text{ of } B \cdot h$$

$$V = 28.26 \cdot 8$$

$$V = \boxed{226.1 \text{ cm}^3}$$

$$\begin{aligned} &\pi \cdot 3^2 \\ &28.26 \end{aligned}$$

46. Concrete can be purchased by the cubic yard. The concrete costs \$35.00 per cubic yard. How much will it cost to pour a cylindrical slab 6 yards in diameter and 9 yards in height? Show you all of your work.

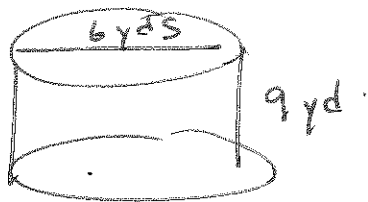

$$V = A_{\text{of } B} \cdot h$$

$$V = 28.26 \cdot 9$$

$$V = 254.34 \text{ yd}^3$$

$$\frac{A_{\text{of } B}}{\pi \cdot 3^2}$$

$$\pi \cdot 9 = 28.26$$

$$\pi \cdot 9 = 28.26$$

$$254.34 \times 35 = \boxed{\$8901.90}$$

47. Calculate the **surface area** of a cone with a vertical height of 8 m and a radius of 4 m. Put your answer to the nearest tenth. Show you all of your work. Be careful.

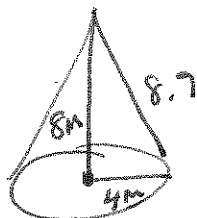

$$\begin{aligned} SA &= \pi r^2 + \pi r l \\ &= \pi \cdot 4^2 + \pi \cdot 4 \cdot 8.9 \\ &= 50.24 + 111.784 \end{aligned}$$

$$\approx \boxed{162.0 \text{ m}^2}$$

$$a^2 + b^2 = c^2$$

$$8^2 + 4^2 = c^2$$

$$64 + 16 = c^2$$

$$\sqrt{80} = c$$

$$c \approx 8.9$$

48. What is the volume of a cone that has a slant height of 6 feet, and a radius of 4 feet? (Answer to the nearest whole number) Show you all of your work. Be careful.

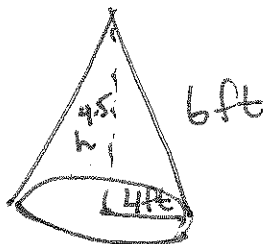

$$V = \frac{1}{3} A_{\text{of } B} \cdot h$$

$$V = \frac{1}{3} \cdot 50.24 \cdot 4.5$$

$$V = \boxed{75.4 \text{ ft}^3}$$

$$\frac{A_{\text{of } B}}{\pi \cdot 4^2}$$

$$50.24$$

$$50.24$$

$$4^2 + h^2 = 6^2$$

$$16 + h^2 = 36$$

$$\sqrt{h^2} = \sqrt{20}$$

$$h \approx 4.5$$